

A D V A N C E D
Collection

INVICTUS
Y A C H T

INVICTUS
YACHT

ASCHENEZ SHIPYARD

The shipyard is a place shaped by people, passion, determination, and unceasing progress, built by those who believe that Quality, together with Beauty, are the most precious - and inexhaustible - resources. The Aschenez Shipyards are where the expertise of those who have created an international benchmark in yachting continues to evolve.

CANTIERI ASCHENEZ

Il Cantiere è un luogo fatto di persone, passione, determinazione e progresso continuo, costruito da chi crede che la Qualità insieme alla Bellezza siano le più preziose - per quanto inesauribili - delle risorse. I Cantieri Aschenez sono il luogo in cui si perpetua l'esperienza di chi ha saputo creare un'eccellenza internazionale nella nautica.

STRUCTURAL MASTERY

Quality and beauty come together in the soft yet powerful lines of Invictus yachts, crafted through a refined construction process. Thanks to the use of carbon fibre and the pre-preg technique, this approach enhances the material's technical, structural, and visual properties, resulting in elevated aesthetics and improved performance.

MAESTRIA STRUTTURALE

Qualità e bellezza si armonizzano nelle forme morbide e possenti delle imbarcazioni Invictus che sono il risultato dello studio di un migliore processo costruttivo che, grazie soprattutto all'impiego della fibra di carbonio e al processo del "pre-peg", ha potuto esaltare le proprietà tecniche, strutturali e visive di questo materiale, che si riflettono in una migliore qualità estetica del prodotto e in migliori prestazioni.





THE EVOLUTION OF MATERIAL

Invictus shapes its vision through a constant pursuit of innovation in materials, where aesthetics, performance, and environmental awareness meet. Among the latest developments by the Aschenez shipyard is the introduction of lightweight, recyclable honeycomb panels, replacing traditional wood in sub-deck walls. This upgrade significantly reduces the overall weight of the yacht, enhancing performance, efficiency, and sustainability. Together with eco-friendly, high-performance finishes and a new approach to interior design focused on atmosphere and comfort, these elements reflect a refined, evolved concept of luxury: contemporary, responsible, and in harmony with the sea.

Once again, Invictus affirms its commitment to a design philosophy that transcends form, a sensorial journey shaped by technical precision, understated elegance, and a sustainable spirit.

L'EVOLUZIONE DELLA MATERIA

La visione Invictus prende forma attraverso una ricerca costante sui materiali, capace di fondere estetica, innovazione e responsabilità. Tra le più recenti novità introdotte dal cantiere Aschenez spiccano i pannelli alveolari strutturali, leggeri e riciclabili, adottati per le pareti sottocoperta in sostituzione del legno tradizionale. Questa soluzione consente di ridurre sensibilmente il peso dell'imbarcazione, migliorandone le prestazioni, l'efficienza e la sostenibilità. Insieme a finiture eco-compatibili ad alte prestazioni e a nuovi concetti abitativi che valorizzano comfort e atmosfera, questi materiali raccontano un'idea evoluta di lusso nautico: contemporanea, responsabile e profondamente connessa al mare. Invictus conferma così la propria vocazione a un design che non è solo stile, ma esperienza sensoriale, equilibrio tecnico ed emozione sostenibile.





GT370



GT370S



GT320



GT320S



GT280



GT280S



TT280



TT280S

Invictus Yachts offer a unique blend of elegance, strength and refined taste. Each model is meticulously designed, with every detail reflecting a commitment to superior quality and a passion for exceptional craftsmanship. The result is yachts that exude sophistication, blending timeless beauty with a commanding presence and effortless, yet bold grace.

Gli yacht Invictus offrono un connubio unico di eleganza, forza e gusto raffinato. Ogni modello è progettato meticolosamente, con ogni dettaglio che riflette un impegno per la qualità superiore e la passione per una lavorazione artigianale eccezionale. Il risultato sono yacht che comunicano raffinatezza, fondendo una bellezza senza tempo con una presenza autorevole e una grazia disinvolta, ma audace.

GT 370

BEYOND BORDERS

With Invictus GT370, luxury evolution doesn't stop. This model has reached new frontiers of beauty and elegance. The distinctive element of this hull is the typical half reverse bow. Here, refinement and power reach the best balance. Invictus GT370 is the peak of luxury and style, customizable with unique elements for a boat of this size, like the opening side converting into a waterfront terrace, the hydraulic platform and a long list of selectable details, made even larger through the Invictus Atelier experience.

OLTRE I CONFINI

Con Invictus GT370, l'evoluzione del lusso non si ferma. Questo modello ha raggiunto nuove frontiere di bellezza ed eleganza. L'elemento distintivo di questo scafo è la tipica mezza prua rovesciata. Qui raffinatezza e potenza raggiungono il miglior equilibrio. Invictus GT370 è l'apice del lusso e dello stile, personalizzabile con elementi unici per una barca di queste dimensioni, come il lato apribile trasformabile in una terrazza sul lungomare, la piattaforma idraulica e una lunga lista di dettagli selezionabili, resa ancora più ampia dall'esperienza di Invictus Atelier.









GT 370S

WITNESS BEAUTY, FEEL THE POWER

With its S version, Invictus GT370 gets complete and shows us a little bit of its cheeky face. The new outboard engines, which can provide up to 1200 Hp, give additional grit to this floating masterpiece, without altering its perfect balance between refinement and power. The "Granturismo" soul gains an extra boost, which does not affect comfort in any way; the cabin, wide and luminous, is the same as the sterndrive version. On the main deck, spaces are comparable to those of larger boats and ensure the best livability and enjoyment for a perfect cruising experience. The optional features add even more versatility; the owner will be able to choose an hydraulic stern platform, openable side bulwarks or even to fully customize the boat through the Invictus Atelier program.

OSSERVA LA BELLEZZA, SENTI LA POTENZA

Con la versione S, Invictus GT370 si completa e ci mostra il suo volto più sfacciato. I nuovi motori fuoribordo, che possono fornire fino a 1200 Hp, danno ulteriore grinta a questo capolavoro galleggiante, senza alterare il suo perfetto equilibrio tra raffinatezza e potenza. L'anima "Granturismo" guadagna una spinta in più, che non compromette il comfort in alcun modo; la cabina, ampia e luminosa, è la stessa della versione entrofuoribordo. Sul ponte principale, gli spazi sono paragonabili a quelli di barche più grandi e garantiscono la migliore vivibilità e divertimento per una perfetta esperienza di navigazione. Le dotazioni opzionali aumentano la versatilità; l'armatore potrà scegliere la piattaforma idraulica di poppa, le plancette laterali apribili o persino personalizzare completamente la barca attraverso il programma Invictus Atelier.









GT 370 / GT 370S

MAINDECK, LOWERDECK AND DETAILS

The majestic spaces are designed to celebrate the style and elegance of a hull conceived to fully enhance the exclusivity of a cruise at sea, without giving up comfort and livability.

MAINDECK, LOWERDECK E DETTAGLI

Gli ambienti maestosi sono progettati per celebrare lo stile e l'eleganza di uno scafo concepito per esaltare appieno l'esclusività di una crociera in mare, che non vuole rinunciare alla comodità e alla vivibilità.







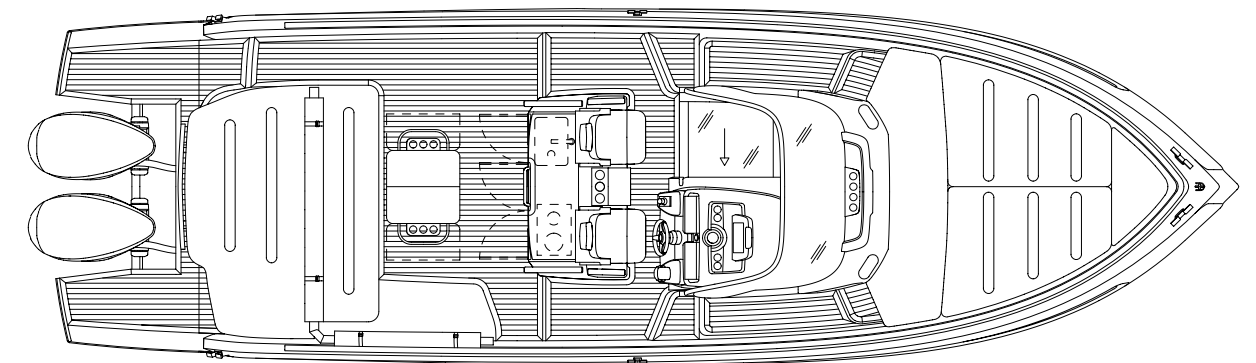
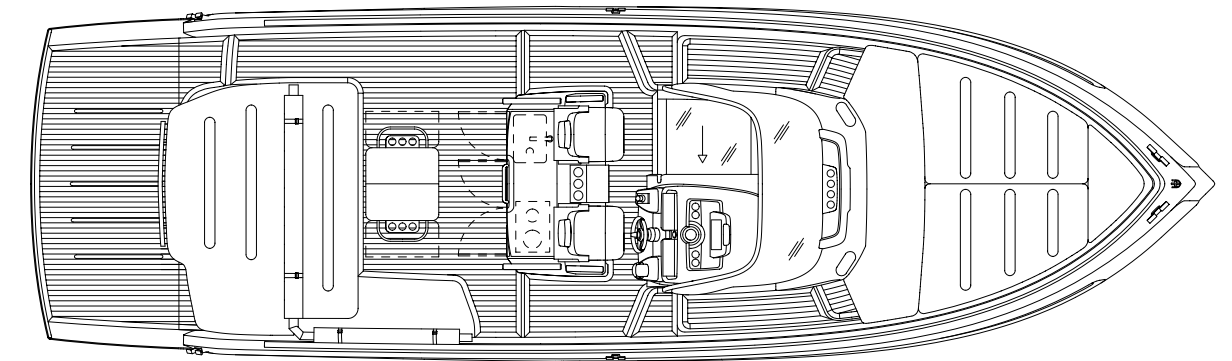
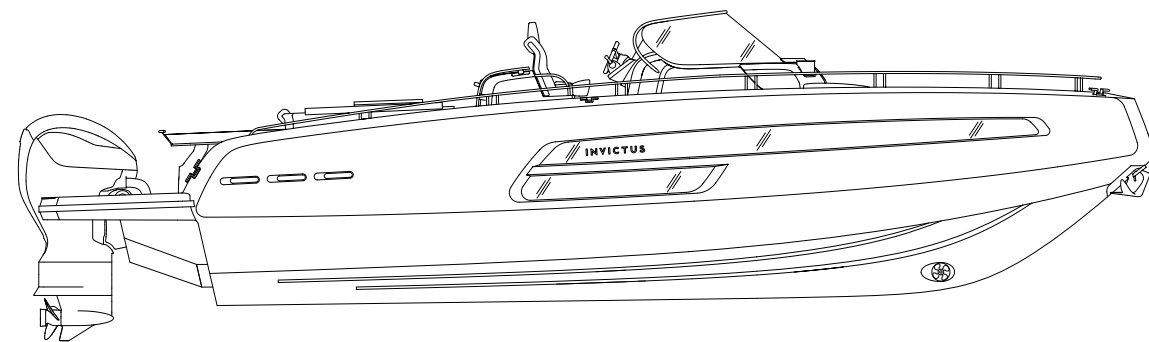
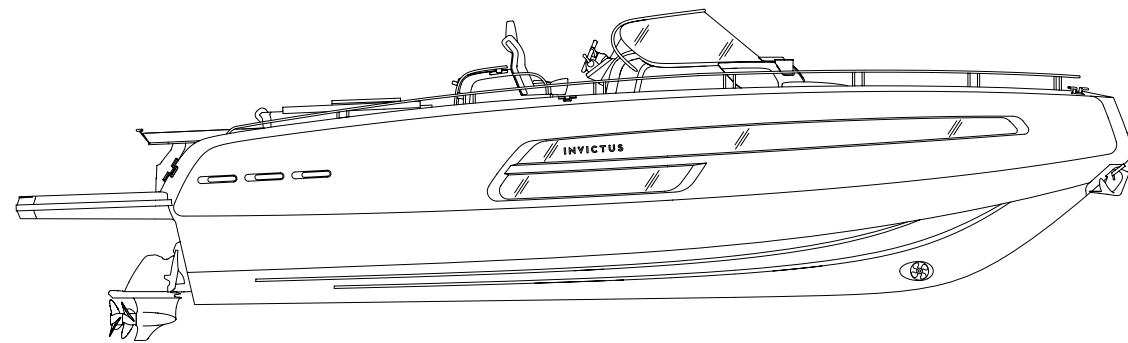

MAIN DECK

- 1 DINETTE/CABIN
DINETTE/CABINA
- 2 CABIN
CABINA
- 3 BATHROOM
BAGNO

	GT370	GT370S
Length overall / Lunghezza fuori tutto	11,4 m	11,35 m
Maximum beam / Larghezza massima fuori tutto	3,5 m	3,5 m
Maximum height / Altezza massima	3,01 / 3,75 m	3,01 / 3,75 m
Displacement Lightship / Dislocamento scarico	6900 kg	6200 kg
Capacity / Portata massima	1350 kg	2200 kg
Person capacity / Numero massimo di persone	12	12
Permitted power / Potenza consentita	860 hp	1200 hp
Design / Design	Christian Grande	Christian Grande

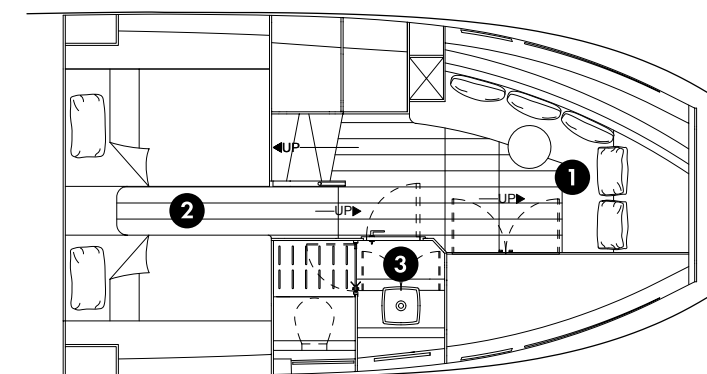

LOWER DECK LOUNGE

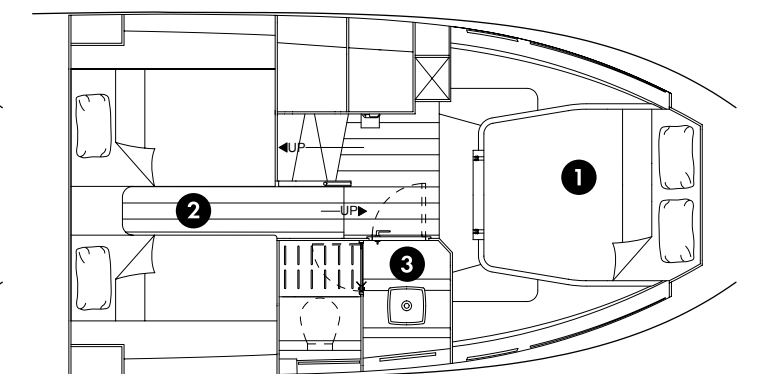

LOWER DECK CABINS



GT370
FIND OUT MORE / SCOPRI DI PIÙ



GT370S
FIND OUT MORE / SCOPRI DI PIÙ

GT 320

STYLE WITHOUT COMPROMISE

Invictus GT320 lies exactly between the series sisters, GT370 and GT280, combining their predominant characteristics: design, comfort, performance. It can be equipped with a single engine, as model GT280, but it is also the smallest in the Invictus range to be equipped with dual motorization, as GT370. The volumes balance and the elegance of lines provide a distinct perception of beauty in every detail. Dimensions do not deny the intention of matching the luxury level of larger boats. The most demanding ship-owners, seeking stylish, comfortable and performing boats will have nothing to give up. Also for GT320, accessories and equipment are customizable with Atelier Invictus proposals.

STILE SENZA COMPROMESSI

Invictus GT320 si colloca esattamente tra le sorelle di serie, GT370 e GT280, unendo le loro caratteristiche predominanti: design, comfort, prestazioni. Può essere equipaggiato con un solo motore, come il modello GT280, ma è anche il più piccolo della gamma Invictus ad essere dotato di doppia motorizzazione, come GT370. L'equilibrio dei volumi e l'eleganza delle linee danno una netta percezione della bellezza in ogni dettaglio. Le dimensioni non negano l'intenzione di eguagliare il livello di lusso delle barche più grandi. Gli armatori più esigenti, alla ricerca di barche eleganti, comode e performanti, non avranno nulla a cui rinunciare. Anche per GT320 accessori e dotazioni sono personalizzabili con le proposte di Atelier Invictus.







GT 320 S

A NEW BALANCE

Invictus GT320S is the new incarnation of balance. Its dimensions represent an excellent synthesis of agility and breadth of spaces; the elegant lines find the right sporty adjective in the design of the outboard engines. Style and power dance together.

UN NUOVO EQUILIBRIO

Invictus GT320S è la nuova incarnazione dell'equilibrio. Le sue dimensioni rappresentano una sintesi eccellente di agilità ed ampiezza degli spazi; le linee eleganti trovano nel disegno dei motori fuoribordo la giusta aggettivazione sportiva. Lo stile e la potenza danzano insieme.







GT 320 / GT 320S

MAINDECK, LOWERDECK AND DETAILS

The attentive management of spaces returns a balanced and refined style. Volumes, materials, and accessories blend naturally, creating a relaxing yet convivial atmosphere.

MAINDECK, LOWERDECK E DETTAGLI

L'attenta gestione degli spazi restituisce uno stile equilibrato e raffinato, in cui volumi, materiali e accessori si fondono in modo naturale, rendendo un'atmosfera rilassante e conviviale al tempo stesso.









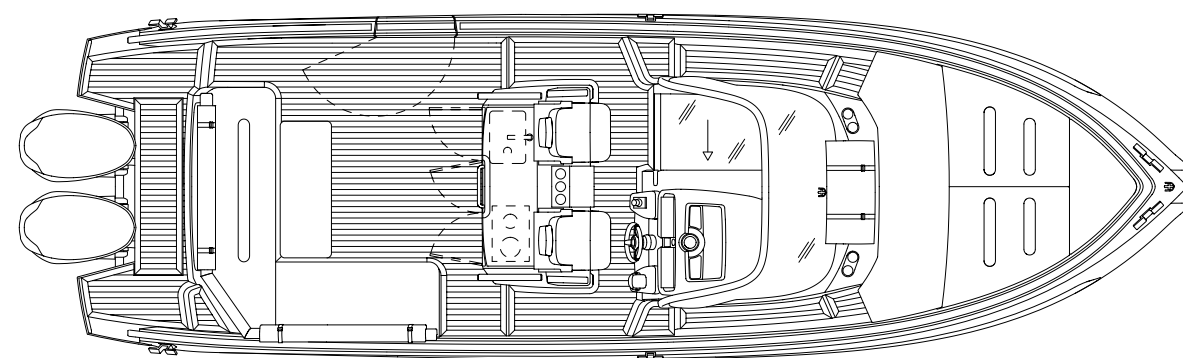
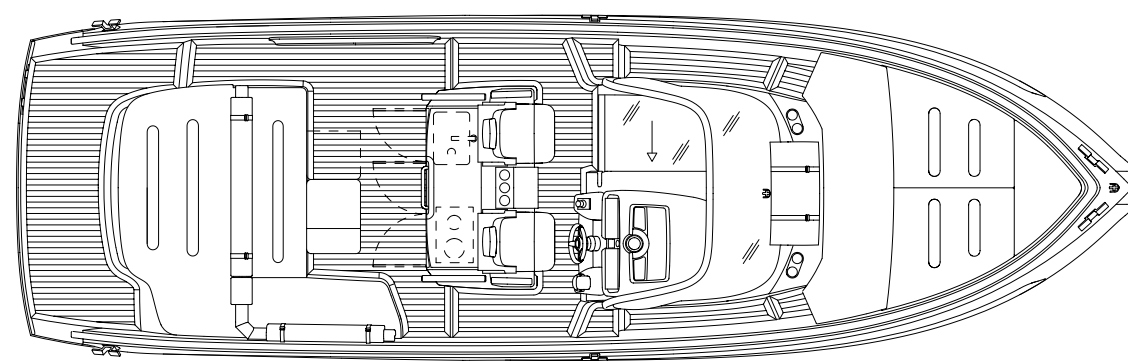
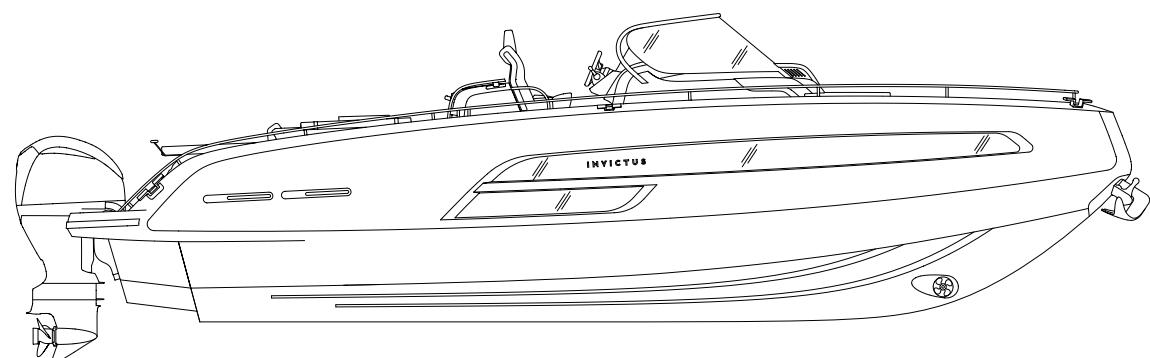
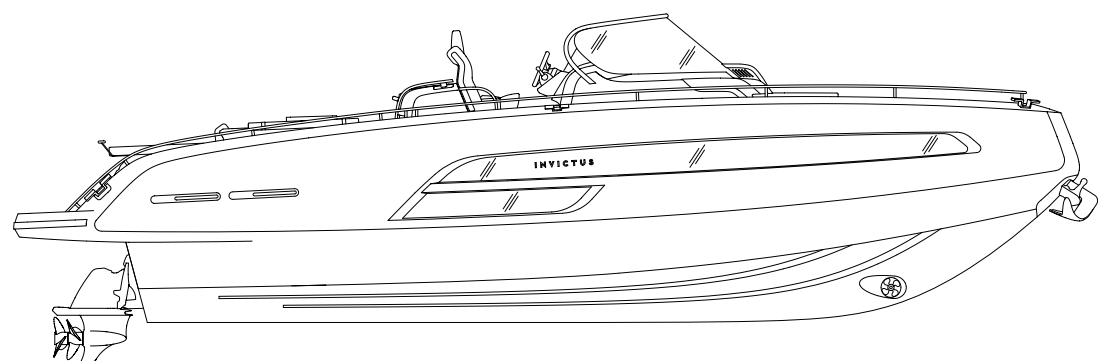

	GT320	GT320S
Length overall / <i>Lunghezza fuori tutto</i>	9,95 m	9,91 m
Maximum beam / <i>Larghezza massima fuori tutto</i>	3,03 m	3,03 m
Maximum height / <i>Altezza massima</i>	2,87 / 3,5 m	2,87 / 3,5 m
Displacement Lightship / <i>Dislocamento scarico</i>	5600 kg	5700 kg
Capacity / <i>Portata massima</i>	1360 kg	2180 kg
Person capacity / <i>Numero massimo di persone</i>	12	12
Permitted power / <i>Potenza consentita</i>	860 hp	900 hp
Design / <i>Design</i>	Christian Grande	Christian Grande

MAIN DECK

- 1 DINETTE/CABIN
DINETTE/CABINA
- 2 CABIN
CABINA
- 3 BATHROOM
BAGNO

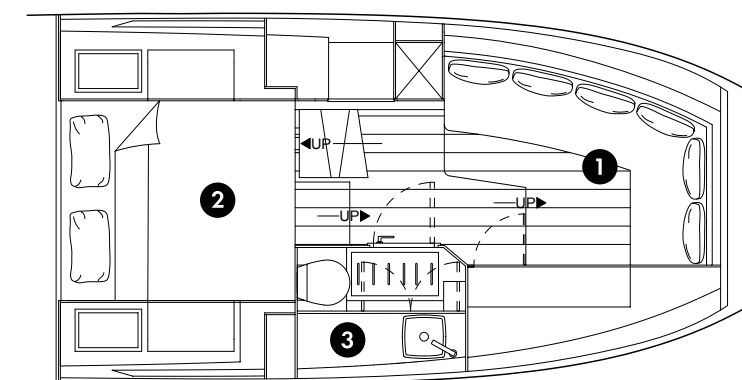

LOWER DECK



GT320
FIND OUT MORE / SCOPRI DI PIÙ



GT320S
FIND OUT MORE / SCOPRI DI PIÙ

GT 280

THE NEW FRONTIER OF DESIGN

GT280, the first born, features a half-reverse bow, sharp and sturdy at the same time. The sides are characterized by homogeneous transitions from solid to empty, while windows and air inlets are designed as simple fissures to stress the monolithic feeling created by Christian Grande. The choice of this bow shape increases the floating length, assuring more longitudinal stability and offering more space and comfort on the lower deck.

LA NUOVA FRONTIERA DEL DESIGN

GT280, la primogenita, presenta una prua semirovescia, affilata e robusta allo stesso tempo. I lati sono caratterizzati da passaggi omogenei dal pieno al vuoto, mentre le finestre e le prese d'aria sono progettate come semplici fessure per sottolineare la sensazione monolitica creata da Christian Grande. La scelta di questa forma di prua aumenta la lunghezza di galleggiamento, assicurando una maggiore stabilità longitudinale e offrendo più spazio e comfort sul ponte inferiore.







GT 280 S

“S” FOR SPORT

“S” for sport. In its new outboard configuration, allowing up to 500 hp engines overall, Invictus first lady adds a thrill to the refined style which has made it well known and appreciated for long. The extraordinary ease of the interiors, the balance of lines, the stability underway do not come to terms: the spaces onboard are tailored to ensure all the comfort which would be usually found on larger boats. Today, beauty will run faster.

“S” PER SPORT

“S” per Sport. Nella sua nuova configurazione fuoribordo, che consente motori fino a 500 CV complessivi, la first lady Invictus aggiunge un brivido allo stile raffinato che l’ha resa nota e apprezzata da tempo. Lo straordinario comfort degli interni, l’equilibrio delle linee, la stabilità in navigazione non scendono a compromessi: gli spazi a bordo sono studiati su misura per garantire tutto il comfort che normalmente si trova sulle barche più grandi. Oggi la bellezza correrà più veloce.











GT280 / GT280S

MAINDECK, LOWERDECK AND DETAILS

The comfortable spaces are designed to ensure unforgettable experiences in line with the Invictus philosophy. This special bow is the result of a precise design process, which provides a significant gain in terms of space and livability.

MAINDECK, LOWERDECK E DETTAGLI

Ambienti confortevoli studiati per garantire esperienze indimenticabili, in linea con la filosofia di Invictus. La particolare conformazione, frutto di uno studio progettuale attento, conferisce notevole guadagno in termini di spazio e vivibilità.





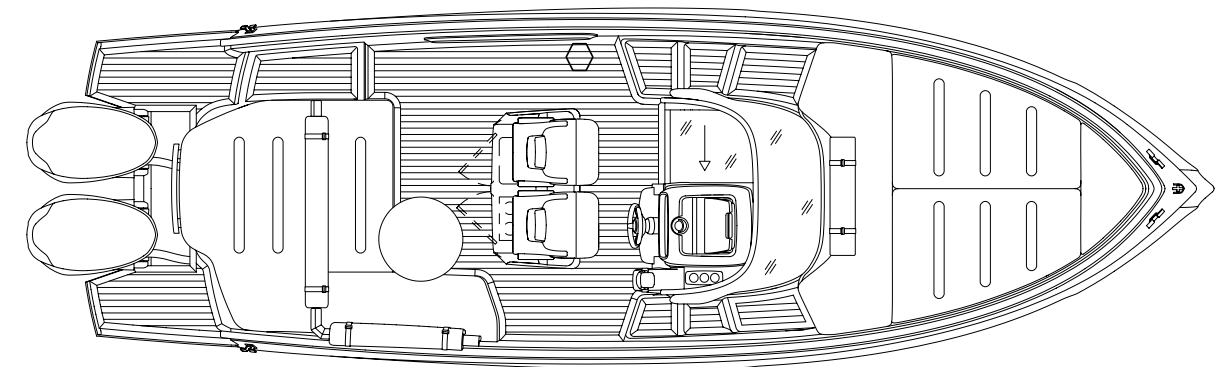
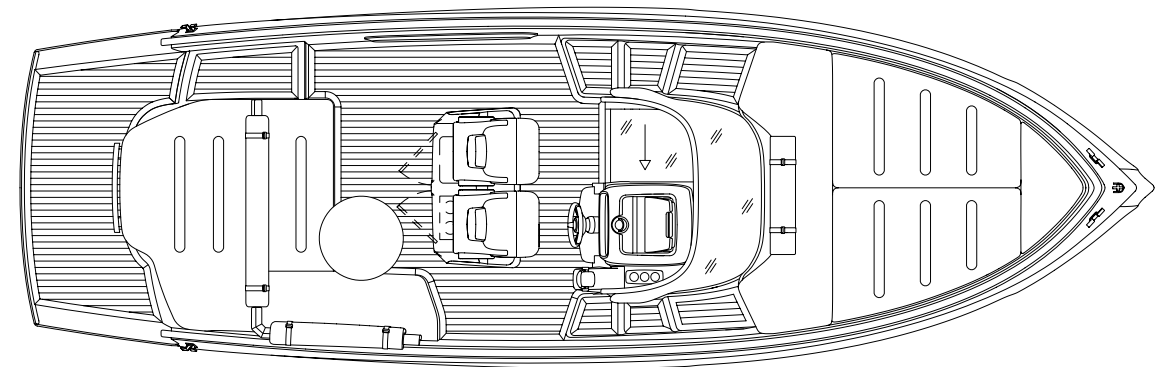
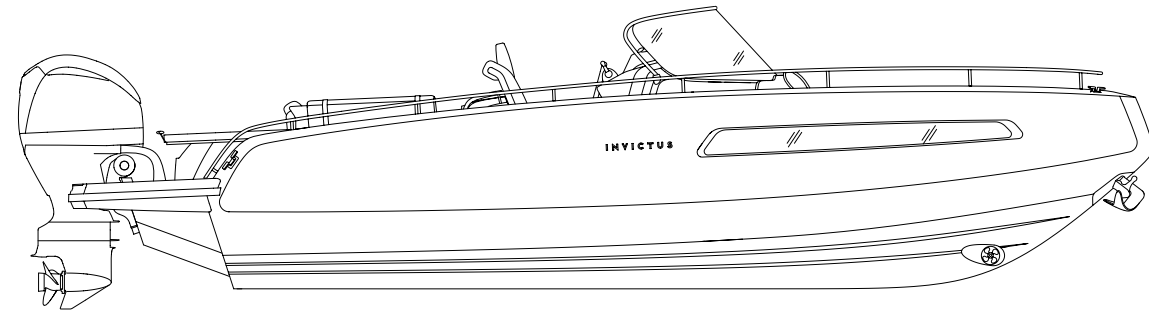
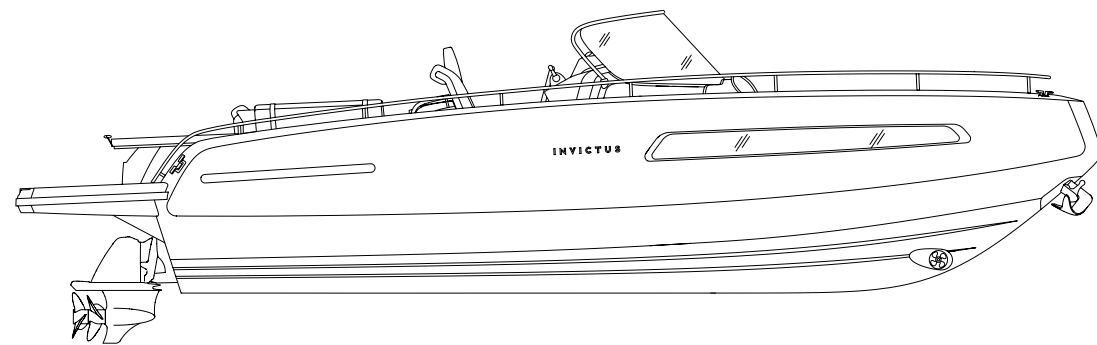

MAIN DECK

- 1 DINETTE/CABIN
DINETTE/CABINA
- 2 BATHROOM
BAGNO

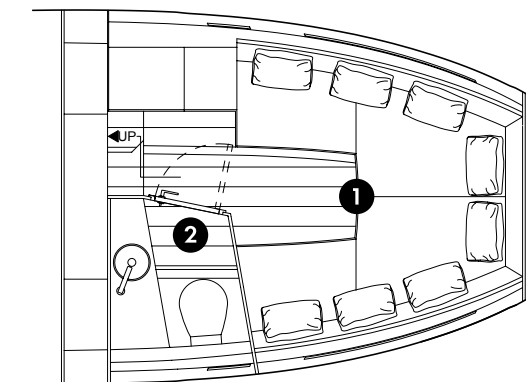

LOWER DECK

GT280

GT280S

Length overall / <i>Lunghezza fuori tutto</i>	8,9 m	8,87 m
Maximum beam / <i>Larghezza massima fuori tutto</i>	2,84 m	2,84 m
Maximum height / <i>Altezza massima</i>	2,27 / 2,84 m	2,27 / 2,84 m
Displacement Lightship / <i>Dislocamento scarico</i>	2800 kg	2400 kg
Capacity / <i>Portata massima</i>	900 - 1080 kg	1000 - 1250 kg
Person capacity / <i>Numero massimo di persone</i>	B8 / C10	B8 / C10
Permitted power / <i>Potenza consentita</i>	350 hp	500 hp
Design / <i>Design</i>	Christian Grande	Christian Grande



GT280
FIND OUT MORE / SCOPRI DI PIÙ



GT280S
FIND OUT MORE / SCOPRI DI PIÙ

TT 280

THE PERFECT SHAPE FOR A TENDER

For owners with no love for compromises, Invictus TT280 makes the perfect boat, both for pure boating as like a maxi-yacht tender. Its vocation of an evolved tender is expressed through balanced combination of refined coatings and comfortable shapes, making this boat a multifunction support vessel. The research of elegance matches functional features, while the half reverse bow offers additional space below deck, to be equipped according to customer needs and desires. Space inside is equipped to offer head, shower and dressing room as one space only, comfortable and organized. Hull sides have an integrated fender system, shaped as the hull in order to give maximum protection and to guarantee good maneuvering. An innovative system, unique and nice as the settings this beautiful boat will come to complement.

LA FORMA PERFETTA DI UN TENDER

Per gli armatori senza interesse per i compromessi, Invictus TT280 è la barca perfetta, sia per la nautica pura che come un maxi-yacht tender. La sua vocazione di tender evoluto si esprime attraverso l'equilibrata combinazione di rivestimenti raffinati e forme confortevoli, facendo di questa barca un mezzo d'appoggio multifunzionale. La ricerca dell'eleganza si sposa con le caratteristiche funzionali, mentre la prua semirovescia offre ulteriore spazio sottocoperta, da attrezzare in base alle esigenze e ai desideri del cliente. Lo spazio interno è attrezzato per offrire soffione, doccia e spogliatoio come un unico spazio, comodo e organizzato. Le fiancate dello scafo hanno un sistema di parabordi integrato, sagomato come lo scafo per dare la massima protezione e garantire una buona manovrabilità. Un sistema innovativo, unico e curato come le ambientazioni che questa bellissima barca verrà a completare.





TT 280 S

MUSCLE AND GRACE

The pleasure of a day of fun on board gets colored with an unprecedented and gritty sporty nuance. With the new outboard configuration and the wide deck and storage spaces, already appreciated in the sterndrive version, TT280S emphasizes a perfect balance between comfort and performance.

MUSCOLI E GRAZIA

Il piacere di una giornata di divertimento a bordo si colora di una sfumatura sportiva inedita e grintosa. Con la nuova configurazione fuoribordo e gli ampi spazi di coperta e stivaggio, già apprezzati nella versione entrofuoribordo, TT280S sottolinea un perfetto equilibrio tra comfort e prestazioni.







TT 280 / TT 280S

MAINDECK AND DETAILS

The spaces are studied in detail to offer a comfortable and organized setting that can be customized through innovative, refined, and unique modular systems. The search for elegance matches the functional features of a balanced and multifunctional tender.

MAINDECK E DETTAGLI

Gli ambienti sono studiati nei minimi dettagli per offrire uno spazio comodo e organizzato che si personalizza attraverso l'uso di sistemi modulari innovati, curati e unici. La ricerca dell'eleganza si sposa con le caratteristiche funzionali di un tender equilibrato e multifunzionale.

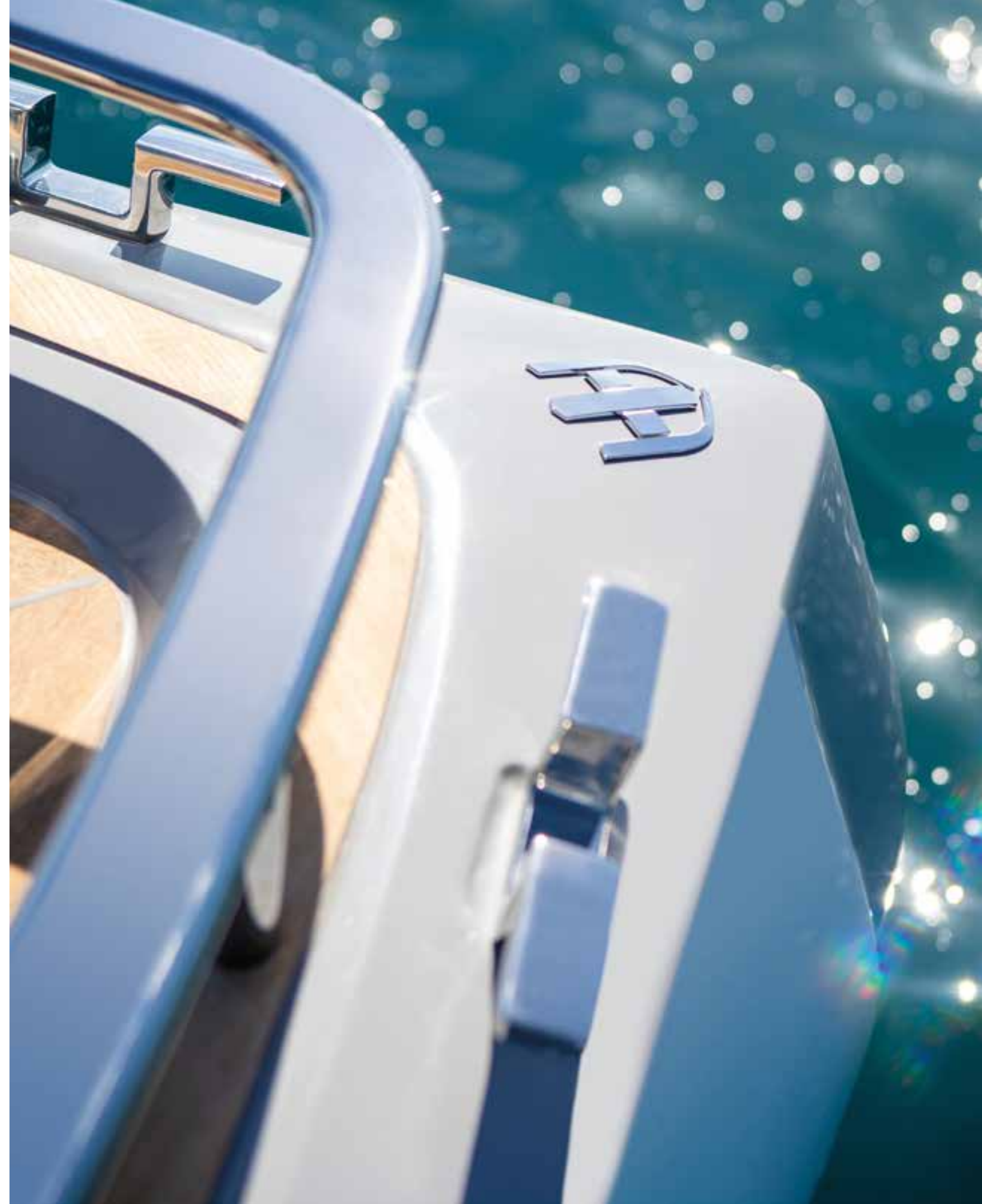



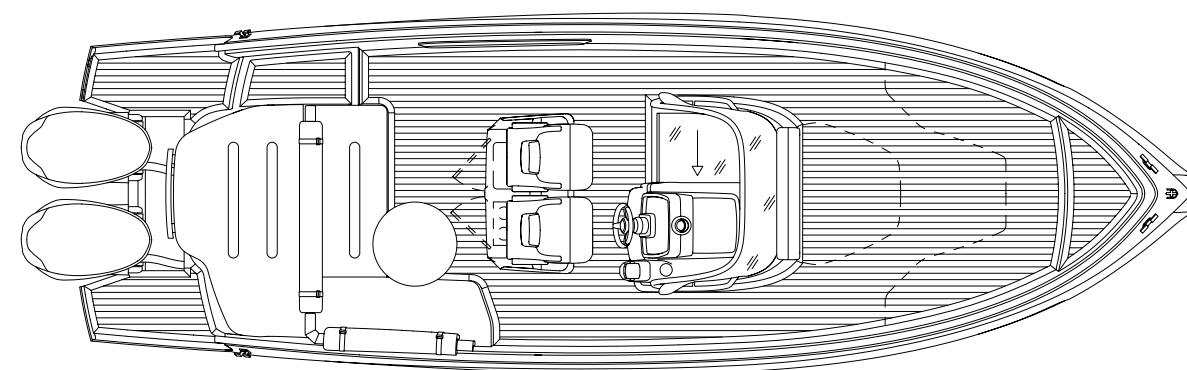
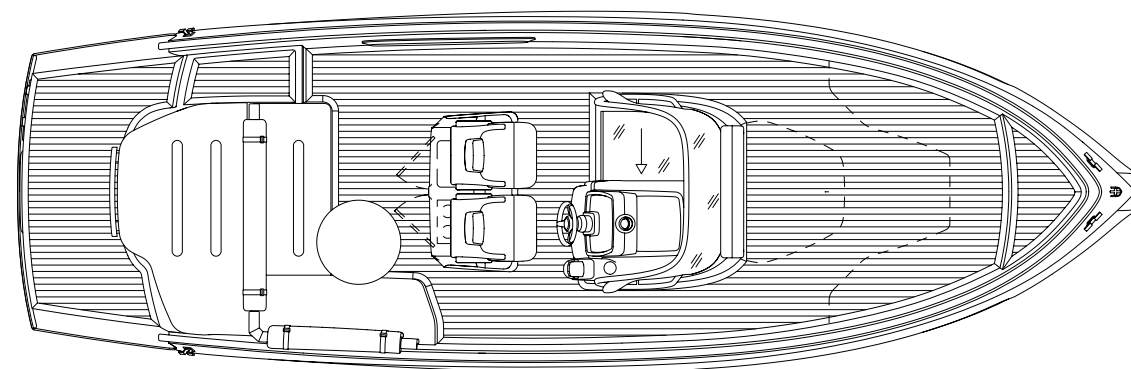
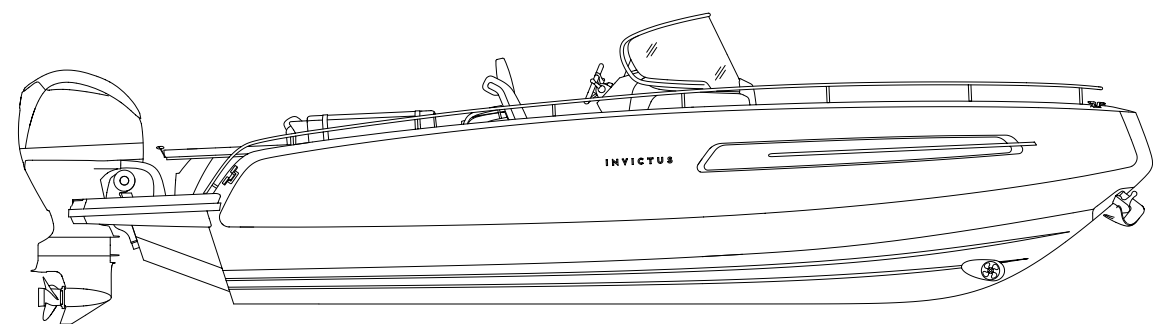
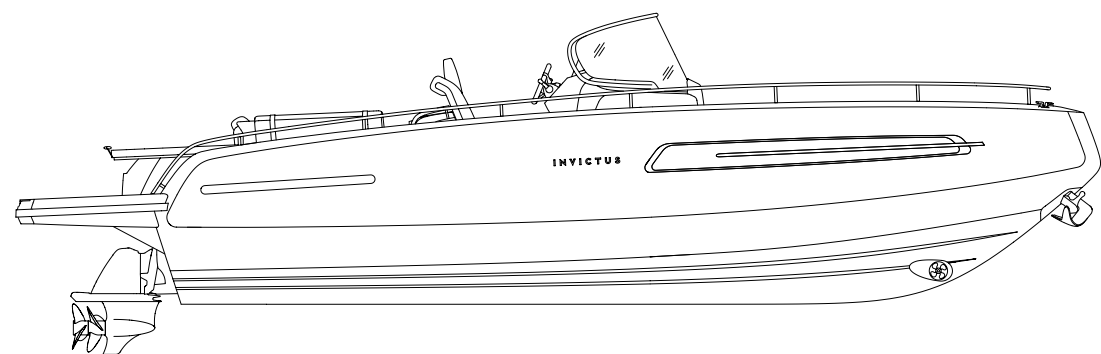

TT280 TT280S

Length overall / Lunghezza fuori tutto	8,9 m	8,87 m
Maximum beam / Larghezza massima fuori tutto	2,94 m	2,94 m
Maximum height / Altezza massima	2,27 / 2,84 m	2,27 / 2,84 m
Displacement Lightship / Dislocamento scarico	2860 kg	2460 kg
Capacity / Portata massima	900 - 1080 kg	1000 - 1250 kg
Person capacity / Numero massimo di persone	B8 / C10	B8 / C10
Permitted power / Potenza consentita	350 hp	500 hp
Design / Design	Christian Grande	Christian Grande

MAIN DECK

1 BATHROOM
BAGNO

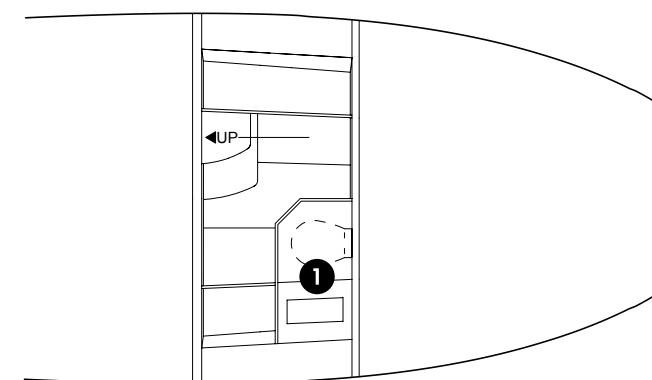

LOWER DECK



TT280
FIND OUT MORE / SCOPRI DI PIÙ



TT280S
FIND OUT MORE / SCOPRI DI PIÙ

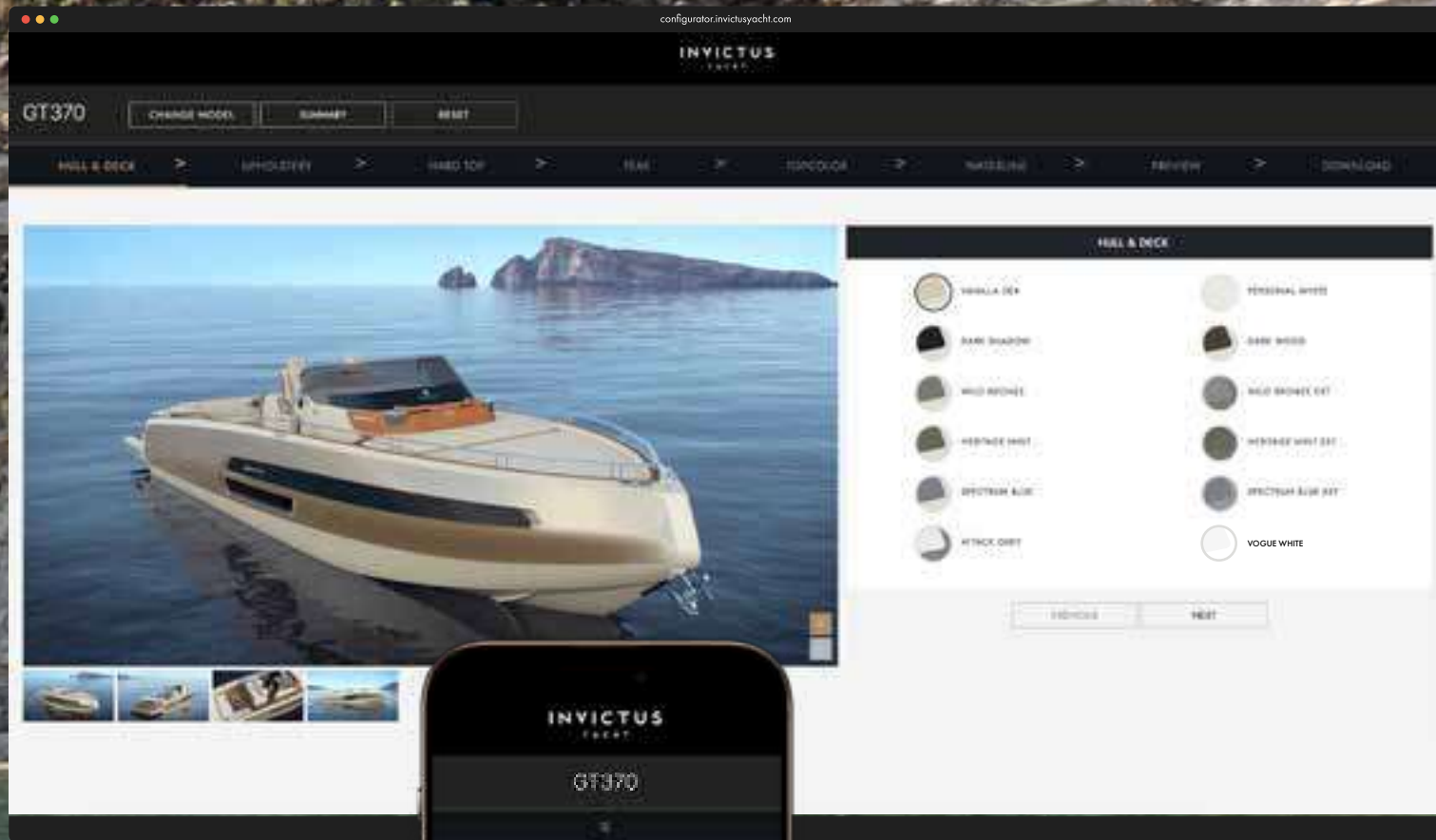

- 
Vanilla Sea

Personal White

Dark Shadow
- 
Wild Bronze

Wild Bronze Extended

Attack Grey
- 
Spectrum Blue

Spectrum Blue Extended

Dark Wood
- 
Heritage Mint

Heritage Mint Extended

Bandit Soul
- 
Vogue White



COLOR MAKES IDENTITY

Each of our boats aspires to be the expression of its owner's soul. The concept of luxury suggested by Invictus Yacht begins with design and extends to color. That's why the shipyard offers extensive possibilities for color customization of its models, with a rich palette of contemporary shades to choose from—making each vessel unique and refined.

Configure your yacht on invictusyacht.com

IL COLORE CREA IDENTITÀ

Ciascuna delle nostre barche desidera essere l'espressione dell'anima del suo armatore. Il concetto di lusso proposto da Invictus Yacht parte dal design e giunge al colore, per questo il cantiere offre ampie possibilità di personalizzazione cromatica dei propri modelli, grazie ad una ricca cartella di colori e tonalità contemporanei tra cui scegliere e tramite cui rendere ogni imbarcazione unica e preziosa.

Configura il tuo yacht su invictusyacht.com





ATELIER

DESIGN YOUR DREAM

Each of our boats wishes to be the expression of its owner's soul. To make every detail a precise image of this will, the world of Atelier Invictus was born; here, every possible customization will be studied and implemented, to make each piece truly unique.

PROGETTA IL TUO SOGNO

Ciascuna delle nostre barche desidera essere l'espressione dell'anima del suo armatore. Per rendere ogni dettaglio l'immagine precisa di questa volontà, è nato il mondo Atelier Invictus; qui, ogni personalizzazione possibile sarà studiata e realizzata, per rendere davvero unico ciascun pezzo.

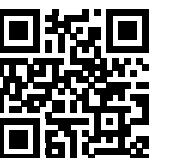

Complete your experience on
Scopri di più su



www.invictusyacht.com

INVICTUS

Y A C H T

Invictus is a brand of Aschenez srl. The company is subject to the management and coordination activity of ASCHENEZ HOLDING S.R.L.
Invictus è un marchio di proprietà Aschenez srl. Società soggetta all'attività di direzione e coordinamento di ASCHENEZ HOLDING S.R.L.

Aschenez srl

Registered Office / *Sede legale* – Via Otranto, 2 88100 Catanzaro (CZ), Italia
Factory and Offices / *Stabilimento ed Uffici* – via Donnici, 28 88021 Borgia (CZ), Italia
Phone / *Telefono* - +39 0961 020388
E-mail / *E-mail* - info@invictusyacht.com

**The images are included for illustrative purposes, are purely indicative and do not constitute a contractual element.
The manufacturer reserves the right to modify its products in this catalog without any prior notice.**

***Le immagini presentate sono inserite a scopo illustrativo, sono puramente indicative e non costituiscono elemento contrattuale.
Il produttore si riserva la facoltà di apportare modifiche ai prodotti del presente catalogo senza alcun preavviso.***

